



NZ TRANSPORT AGENCY
WAKA KOTAHI

NZTA Standards and guidelines

Bob Gibson, Principal Engineer, Network Standards and Safety

Introduction

Road marking should communicate messages through a uniform system of colours, patterns, widths, symbols and words.

Uniformity makes it possible for drivers to quickly recognise meaning and react appropriately.

A small case study – continuity lines

Do we have consistency in marking continuity lines?

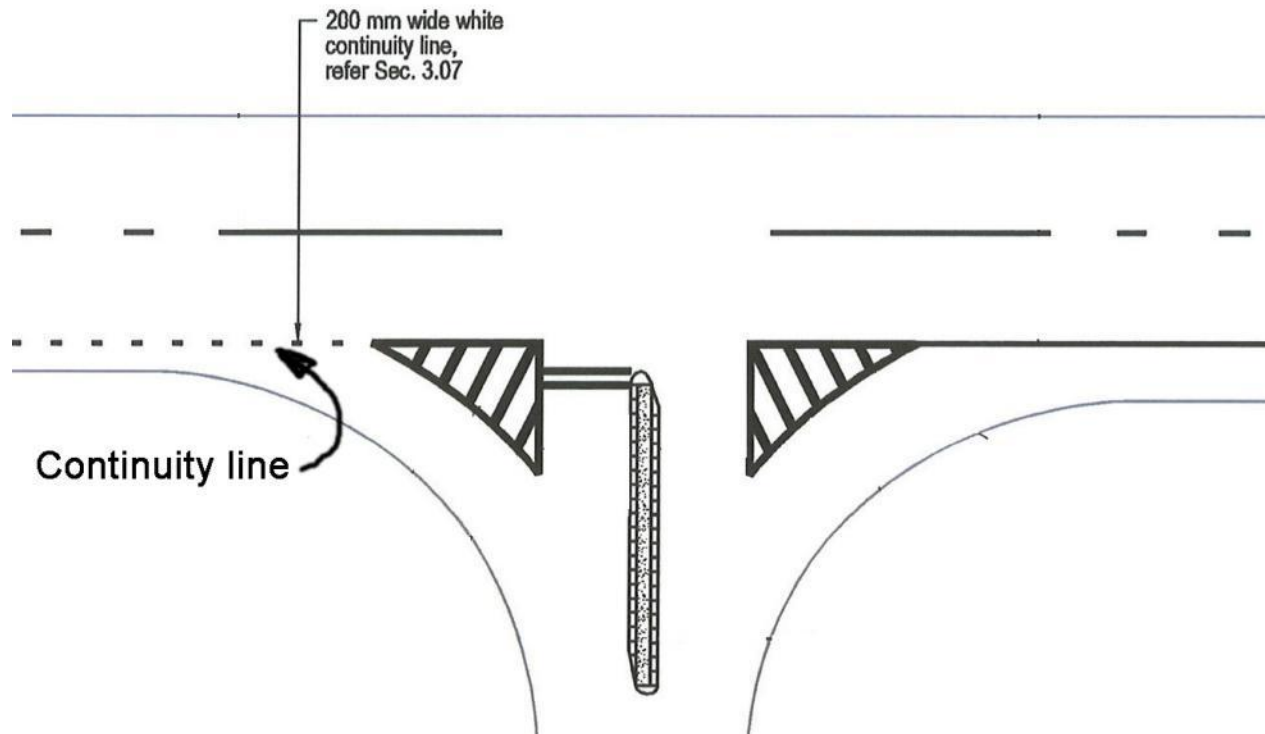

A small case study – continuity lines

Do we have consistency in marking continuity lines?

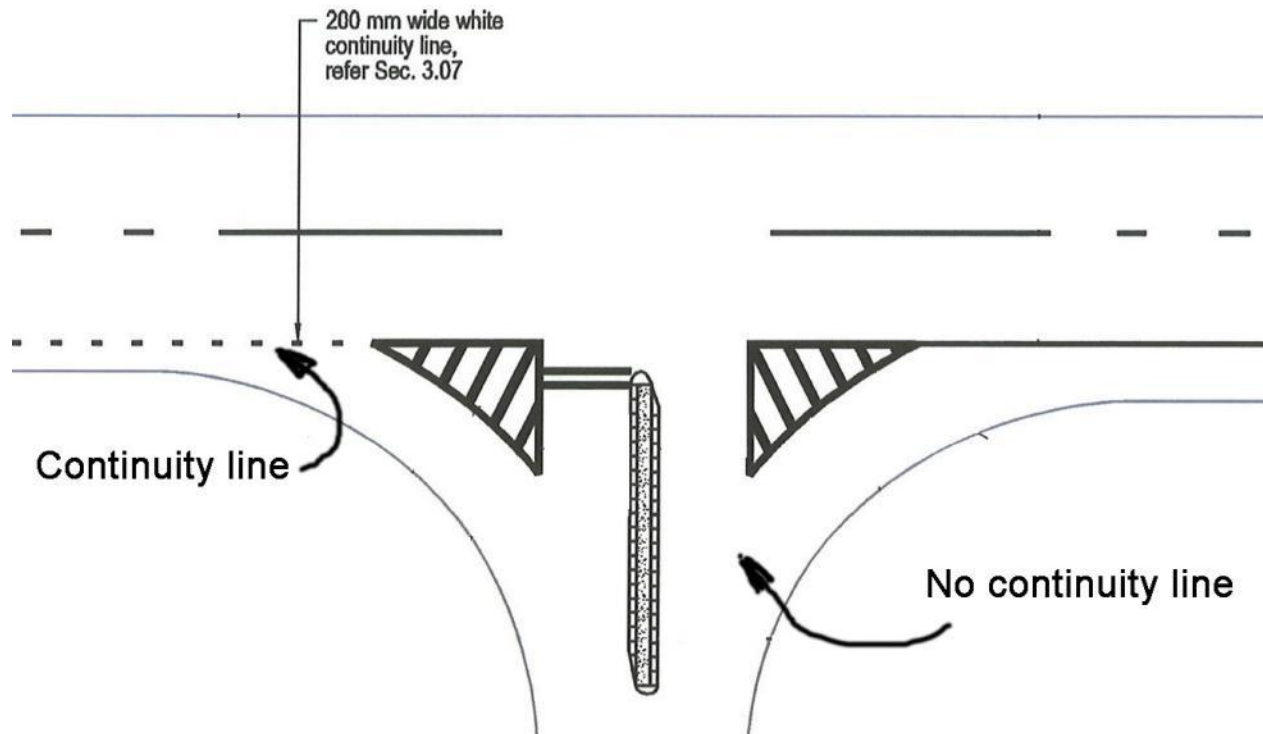

A small case study – continuity lines

Termination of passing lane

No continuity line

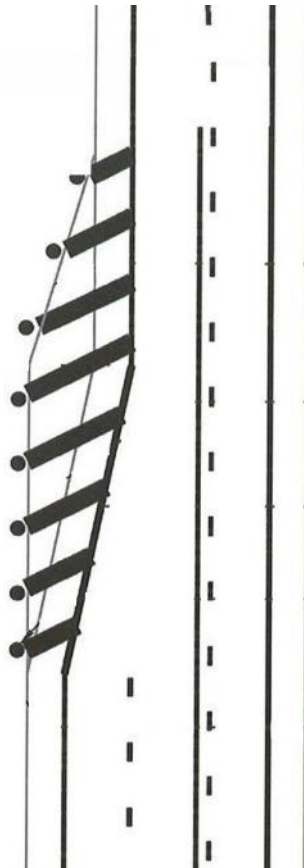

A small case study – continuity lines

Termination of passing lane or 'slow vehicle' lane

No continuity line



Continuity line



Legislation

Historical

- *Traffic Regulations 1936*
- *Pedestrian-crossing and Safety-zone Regulations 1939*
- *Traffic Regulations 1976*

Land Transport Act 1998

- provision to make rules
- consultation
- safety at reasonable cost

Land Transport Rules: Traffic Control Devices 2004

- industry consultative group
- public consultation
- Amendment Rule 2010



Overseas practices

Multi-national conventions and agreements

Examples of international form of markings

- Centre lines – dashed or continuous, yellow or white
- No passing lines – continuous single or double line
- Limit lines – continuous, dashed or patterned

Europe (particularly UK) and North America (US / Canada)

Australia

- Austroads Guides



New Zealand standards and guidelines

Manual for traffic control devices

- 22 parts
- Part 4 *General requirements for markings*
- Working groups representative of practitioners

NZTA standards and guidelines register

- Definitive list of manuals and technical documents
- Standards, guidelines and ‘other documents’
- Web-based

Process manual for the register

- Rules for managing each type of document
- Procedures for allowing variations



NZTA Standards and Guidelines

bob.gibson@nzta.govt.nz



NZ TRANSPORT AGENCY
WAKA KOTAHI

New Zealand Government