

Creating Star Performers



**InfraTrain**  
**New Zealand**

# InfraTrain New Zealand

## InfraTrain Update

Ross Leslie, National Operations Manager



# 2008 Training Achievements

- InfraTrain supported trainees – 6,139
- Modern Apprentices – 240
- Companies – 515 across 12 industry sectors
- Certificates completed – 765
- InfraTrain provided subsidies - \$1,589,565



# Enrolled Qualifications

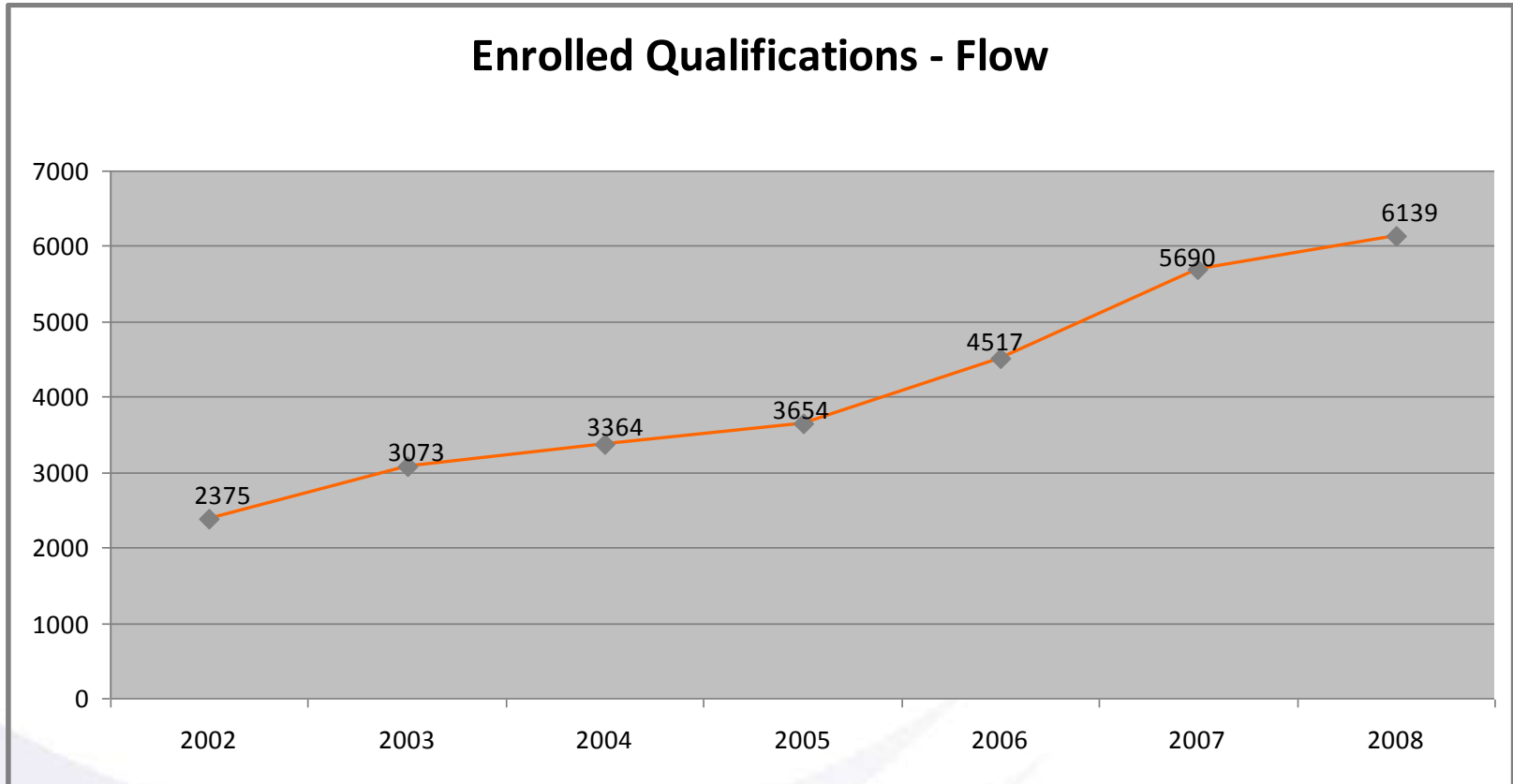

# Qualification Completions

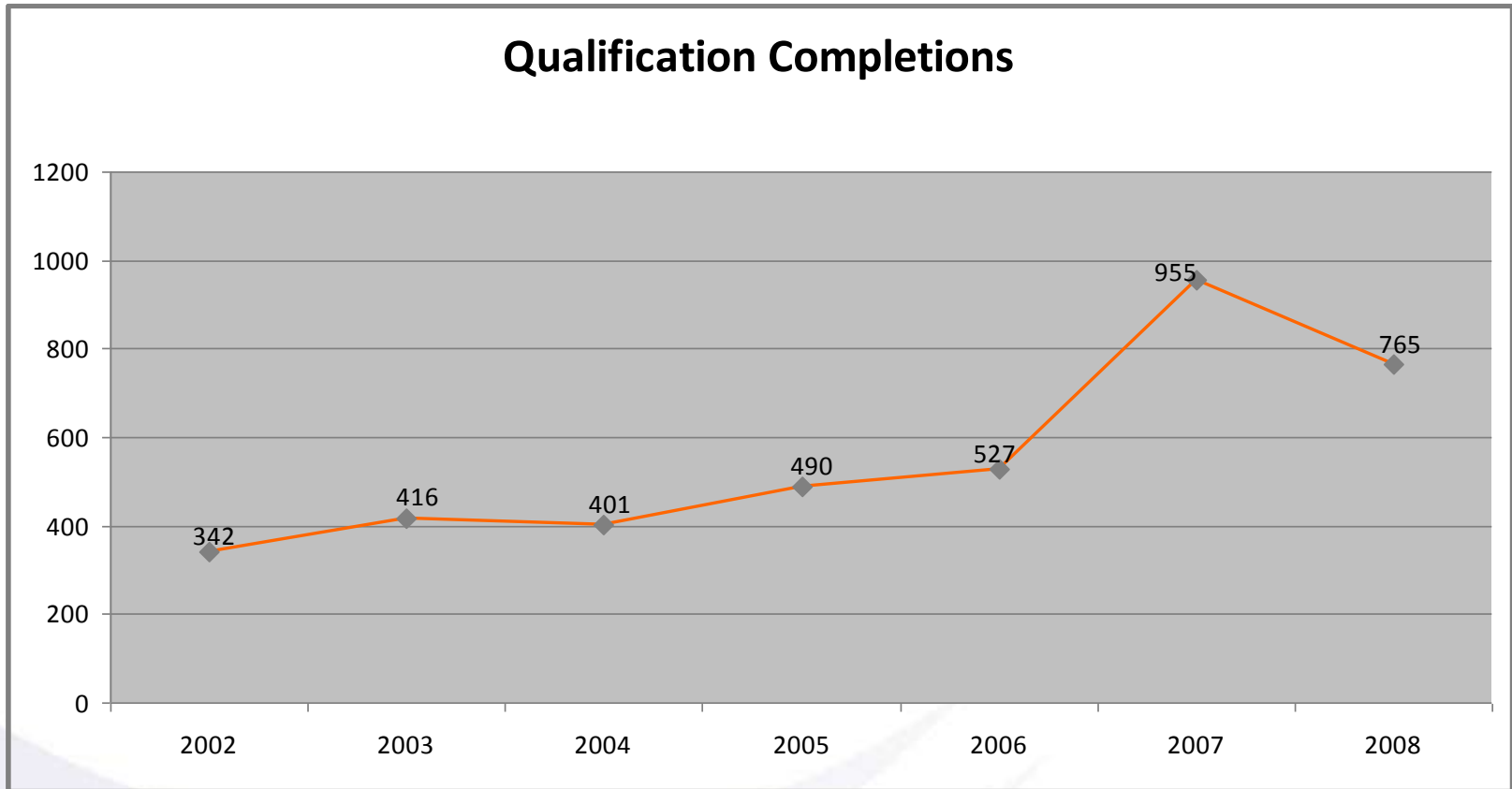

# InfraTrain Funding & Training Delivery

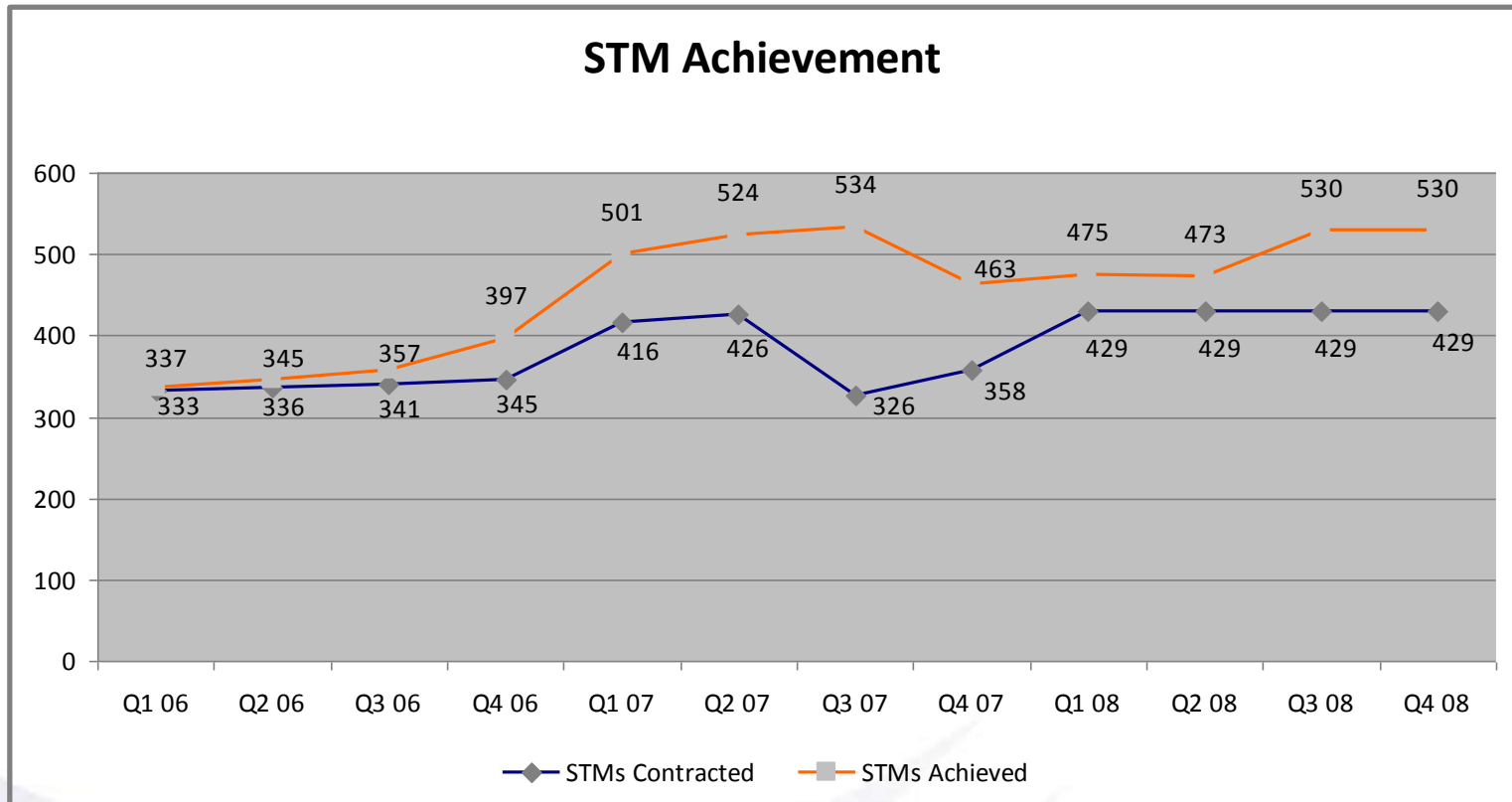

# Projected Growth in Industry Training & Funding

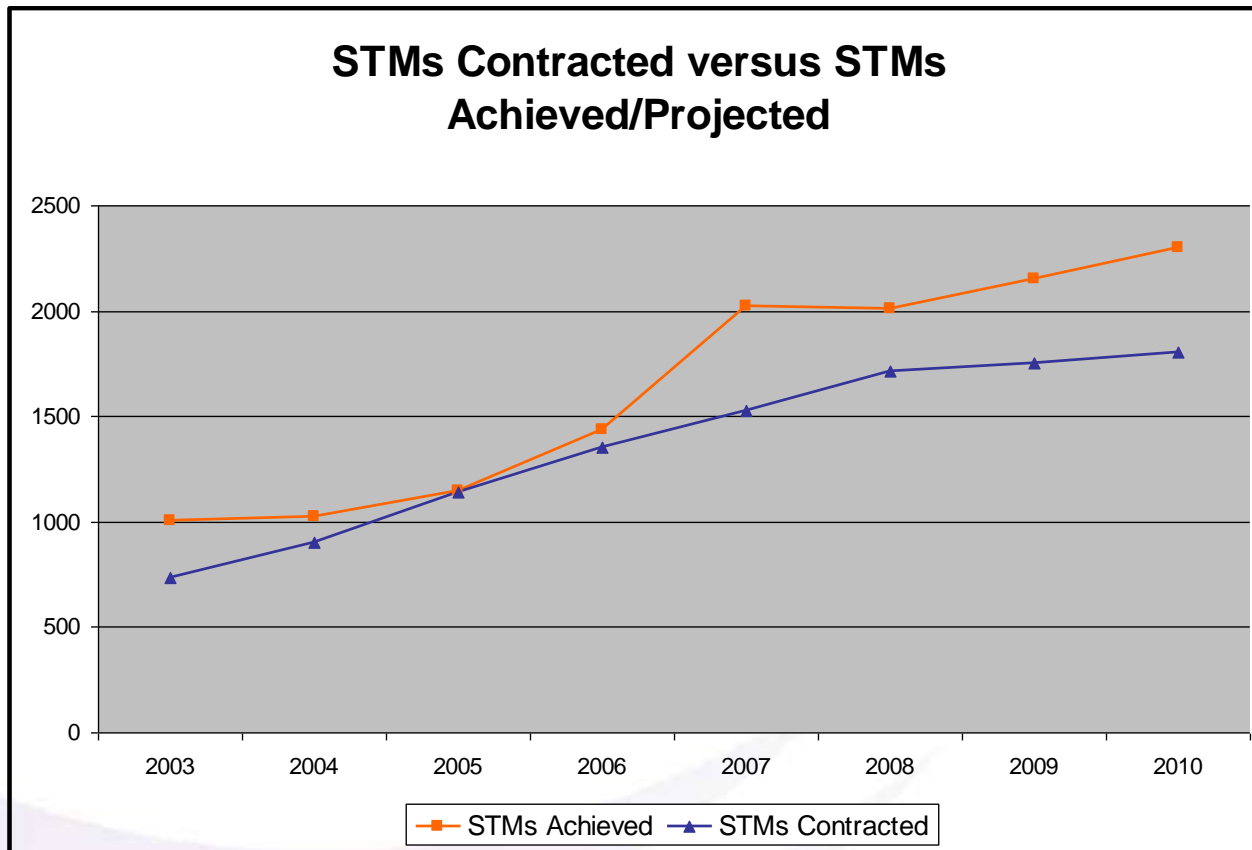

# New Roadmarking Qualifications

New National Certificates covering:

- Assistant L2 or 3
- Operator L3
- Senior Operator L3 or 4



# New Roadmarking Qualifications

- Incorporate best practice in materials handling, traffic control
- Aligned with traffic management requirements of NZTA and Local Government
- Can be gained on-job
- Qualifications are subsidised

# New Roadmarking Qualifications

- Provide choice - flexibility to suit job requirements
  - Core compulsory unit standards
  - Core elective unit standards
  - Optional strands
- Some common unit standards between quals to suit company operations

# New Roadmarking Qualifications

Pathway or direct entry:

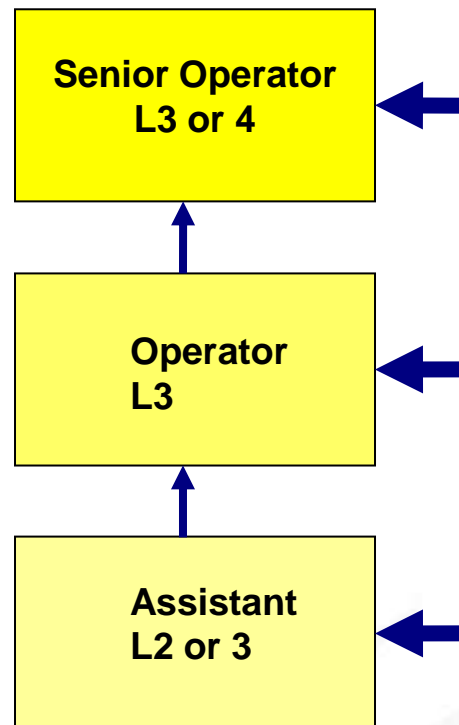

## Assistant Level 2 or 3

- For people working in a support role in a roadmarking crew
- Compulsory unit standards covering:
  - Materials, plant & processes
  - Roadmarking assistant tasks
  - Communication, First Aid
  - H,S & E requirements, HSNO approved handler
  - Class1 with DG endorsement, fire & load loss response
  - TC for Level 1 roads

## Assistant Level 2 or 3 (contd)

- Elective unit standards complete qualification – selected from H,S & E units
- In addition, one or more optional strands can be done
  - Piloting
  - Raised markers
  - Thermoplastics
  - Transport

## Operator Level 3

- For operators doing remark work with A or B-type applicator
- Compulsory unit standards covering:
  - Roadmarking specs, calculations, records
  - Location, set out & management of simple sites
  - QA & sampling
  - Plant checks & maintenance
  - Class1 with DG endorsement, fire & load loss response, First Aid
  - TC and STMS for Level 1 roads

## Operator (contd)

- Elective unit standards selected from wide range of H,S & E units
- Qual completed with strand in either A-type or B-type applicators
- In addition, one or more optional strands can be done
  - Raised Markers, TTM Level 2 & 3 roads, Transport

## Senior Operator Level 3 or 4

- For skilled operators doing new or remark work with A or B-type applicator
- Compulsory unit standards covering:
  - Materials, processes & specs for complex work
  - Maps & plans for plant operation
  - Complex set out & calculations
  - Supervision & management of projects
  - Managing H,S & E requirements



## Senior Operator (contd)

- Elective unit standards selected from wide range of H,S & E units
- Qual completed with strand in either Long-life Products or Paint Marking
- In addition, one or more optional strands can be done
  - TTM Level 2 & 3 roads
  - Testing NZTA/NZRF T/8 or T/12

# Resources



# Resources



# Regional support

- 10 regional offices



# InfraTrain Achievements

- Strategic Advisory Committee
- Literacy and Numeracy
- Pre-employment courses
- Te Puni Kokiri



# Strategic Advisory Committee

- Strategic advisory committee established, initially with Civil/Bitumen
- Role of committees will be to produce the industry training plans
- Operational committees will work with InfraTrain and provide advice on implementing these

## Te Puni Kokiri

- Maori in Industry and Trades Training – new initiative launched with InfraTrain
- Auckland, Northland, Waikato, East Cape, Hawkes Bay
- Work with new trainees to gain skills and qualifications
- Support Maori in the industry to gain higher-level qualifications

Creating Star Performers



**InfraTrain**  
**New Zealand**